

# LexSciBowl

## Physics Test

Assume  $g = 10 \text{ m/s}^2$ . Answers without units will be marked incorrect.

### Units

- 1) [4] Name the SI units for each of the following:
  - a) Time
  - b) Force
  - c) Temperature
  - d) Electromotive force
  - e) Frequency
  - f) Luminous intensity
  - g) Electrical resistance
  - h) Magnetic field strength
- 2) [1] What unit is defined as the average distance between the sun and the earth?
- 3) [3] One second is defined by the hyperfine transition frequency of what element?

### Newtonian Mechanics

- 4) [1] What quantity is the time derivative, or rate of change, of velocity?
- 5) [2] The coefficient of static friction on a surface is 0.8 and the coefficient of kinetic friction on the surface is 0.6. A block is placed on this surface initially at rest and then pushed to the right with a force gradually increasing from zero. Which of the following correctly describes the movement of the block?
  - a) The block accelerates with constant acceleration.
  - b) The block accelerates, asymptotically approaching some maximum velocity.
  - c) The block accelerates, asymptotically approaching some maximum acceleration.
  - d) The block first accelerates, then at some point abruptly stops.
  - e) The block first remains at rest, then at some point abruptly begins accelerating.
- 6) [2] In perfectly inelastic collisions:
  - a) Kinetic energy and momentum are conserved.
  - b) Kinetic energy is conserved, but momentum is not conserved.
  - c) Kinetic energy is not conserved, but momentum is conserved.
  - d) Neither kinetic energy nor momentum are conserved.
- 7) [1] What is the gravitational potential energy of an object of mass 5 kilograms at a height of 10m?
- 8) [1] A spring has a force constant of 40 N/m. What force is exerted by the spring if it is displaced 25 cm past its equilibrium length?
- 9) [4] A block of mass 3 kg starting at rest undergoes a constant acceleration of  $2 \text{ m/s}^2$ .
  - a) What is the velocity after two seconds?
  - b) What must be the net force applied to maintain this acceleration?

- c) What is the magnitude of the momentum of this object after 5 seconds?
  - d) What is the kinetic energy of this object after 5 seconds?
- 10) [2] What centripetal gravitational force must be exerted on a satellite orbiting the Earth in a circular orbit if its mass is  $m$ , velocity  $v$ , and radius of orbit is  $r$ ?

## Waves and Optics

- 11) [1] What phenomenon occurs when two waves differing in phase cancel each other out?
- 12) [1] What is the period of oscillation of a wave with wavelength 4 meters and frequency 2 hertz?
- 13) [2] What property of light is often used in 3D movies to allow the screen to show slightly different images to each eye (stereoscopic vision), and has linear, circular, and elliptical varieties?
- 14) [4] An object is placed in front of a convex mirror. Select any or all of the following which can possibly be true about the image.
- a) Real
  - b) Virtual
  - c) Upright
  - d) Inverted
  - e) Magnified
  - f) Diminished

## Fluids & Thermodynamics

- 15) [1] What principle named after a French physicist states that the sum of the potential energy, kinetic energy, and pressure energy of a non-compressible fluid is constant, and is often used to calculate lift on airplane wings?
- 16) [1] What is the name for the temperature and pressure at which solid, liquid, and gas states of matter exist at the same time?
- 17) [1] A gas does 30 J of work and absorbs 45 J as heat. What is the change in internal energy of the gas?
- 18) [2] Absolute zero is approximately what temperature in Celsius?
- 19) [2] To the nearest degree Celsius, at what temperature is water is at its maximum density?
- 20) [2] The Second Law of Thermodynamics states that what quantity always increases?

## Electricity & Magnetism

- 21) [1] Find the electromotive force in a simple circuit with 20 ohms resistance and a current of 5 amperes.
- 22) [2] Find the power dissipated by a 15-ohm resistor with a voltage of 90 volts across it.
- 23) [2] If a positively charged particle is traveling due north through an electric field pointing upward, in which direction will the particle be deflected?
- 24) [2] If a positively charged particle is traveling due north through a magnetic field pointing upward, in which direction will the particle be deflected?
- 25) [2] Suppose we have a parallel plate capacitor. Which of the following will increase the capacitance?
- a) Replacing the air inside the capacitor with a vacuum

- b) Increasing the plate surface area
  - c) Increasing the distance between the plates
- 26) [2] What law results in the nonexistence of magnetic monopoles?
- 27) [3] What effect excludes lines of magnetic field from entering a superconductor?

## Particle Physics

- 28) [1] List all 5 major states of matter.
- 29) [1] What are the three quark constituents of the proton?
- 30) [2] Which boson mediates the electromagnetic force?
- 31) [2] There are many types of nuclear reactors. What type of reactor surrounds the main reactor chamber with uranium-238 to absorb neutrons and breed fissile plutonium-239 is known as what type of nuclear reactor?
- 32) [3] What are the three products of beta-minus decay?

## Astrophysics, Relativity, and Modern Physics

- 33) [1] Name the two physical forces that result in hydrostatic equilibrium in a star.
- 34) [2] What law states that galaxies further away are always receding more quickly?
- 35) [2] What specific type of galaxy is the Milky Way?
- 36) [2] What stellar spectral type is the hottest?
- 37) [3] An object of length 300 meters travels at  $0.8c$ , where  $c$  is the speed of light. According to Special Relativity, what is the length of the object in a stationary reference frame?

## Scientists & the History of Science

- 38) [1] Which physicist that provided an explanation for Brownian motion, won a Nobel Prize for his explanation of the photoelectric effect, and developed the theories of special and general relativity?
- 39) [2] What famous experiment showed the wave nature of light by diffracting light through two closely spaced slits and observing the interference pattern formed?
- 40) [2] Which physicist formulated a classical theory of electromagnetic radiation, whose namesake equations form the basis of electricity and magnetism?

## Challenge Problems

- 41) [5] An object starting from rest slides down a frictionless ramp from a height of 2 meters, onto a flat, frictionless surface with a height of 0 meters. At the bottom, there is a spring which has a spring constant of  $k$ , which is compressed 0.1 meters by the sliding object.
- a) If the object's mass is 5 kilograms and all forms of friction are negligible, find  $k$ .
  - b) At the moment of the spring's compression, the ramp is removed. The spring releases the object and it continues to slide at velocity  $v$ . Find  $v$ , in simplest radical form.
- 42) [5] Clive tosses a javelin across level ground with an initial speed of 20 m/s at an angle of  $30^\circ$  to the horizontal. Assume  $g = 10 \text{ m/s}^2$  and air resistance is neglected.
- a) Assuming Clive initially tosses the javelin from ground level, what is the maximum height the javelin achieves?

b) How far does the javelin travel horizontally?

43) **[8]** London Bridge is about 250 metres long and mostly made of concrete, which has a coefficient of thermal expansion of  $12 \times 10^{-6} \text{ K}^{-1}$ . Two thermal expansion joints are located at the ends of the bridge to allow for expansion, as pictured.

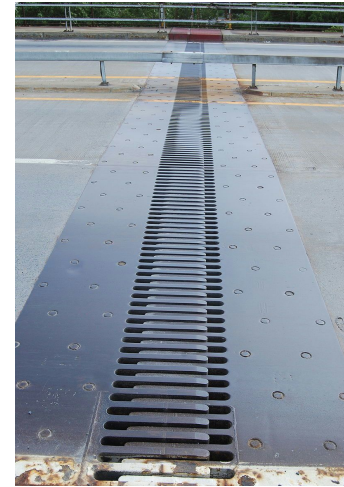

- a) One chilly morning, it is 5 degrees Celsius. By late afternoon, it has warmed up to 25 degrees Celsius. By how much does the length of the bridge increase?
- b) The Young's modulus  $E$  of concrete is 40 megapascals. The cross-sectional area  $A_0$  is 10 square meters. What would the compressive force exerted along the length of the bridge be if there were no thermal expansion joints and the bridge did not flex vertically? Use the following equation.

$$F = \frac{EA_0\Delta L}{L_0}$$

44) **[10]** As shown in the figure on the right, an object A exists with mass  $M$  on a frictionless surface, with object B with mass  $m$  upon the side of object A. Object A is being pushed with a force of  $F$ . If the gravitational acceleration is  $g$  and the static friction coefficient is  $\mu$ , what is the minimum value of  $F$  required in order to prevent object B from sliding to the ground, in terms of any or all of  $M$ ,  $m$ ,  $\mu$ , and  $g$ ?

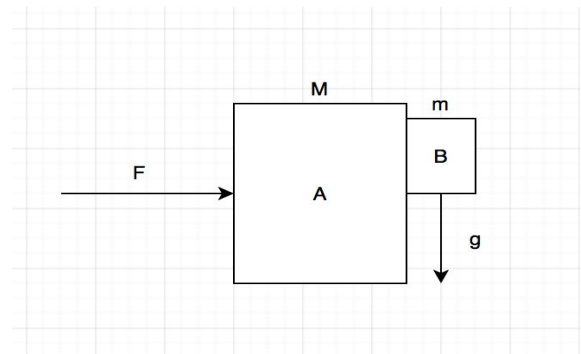

45) **[15]** The Lorentz Force Law states that the force exerted by a magnetic field on a charged particle is perpendicular to the motion of the particle and to the direction of the field, and has magnitude  $F = qv \times B$ , where  $F$  is force in newtons,  $q$  is charge in coulombs,  $v$  is velocity in meters per second, and  $B$  is magnetic field in teslas.

A point charge of 0.2 coulombs and mass 50 kilograms moving to the right with speed 40 m/s enters a large magnetic field of magnitude 0.5 teslas directed into the page. As a result, the charge's path changes to a circle perpendicular to the magnetic field with radius  $R$ . Find  $R$ .